

ELECTRONIC CONTROL BOX EC-12-01

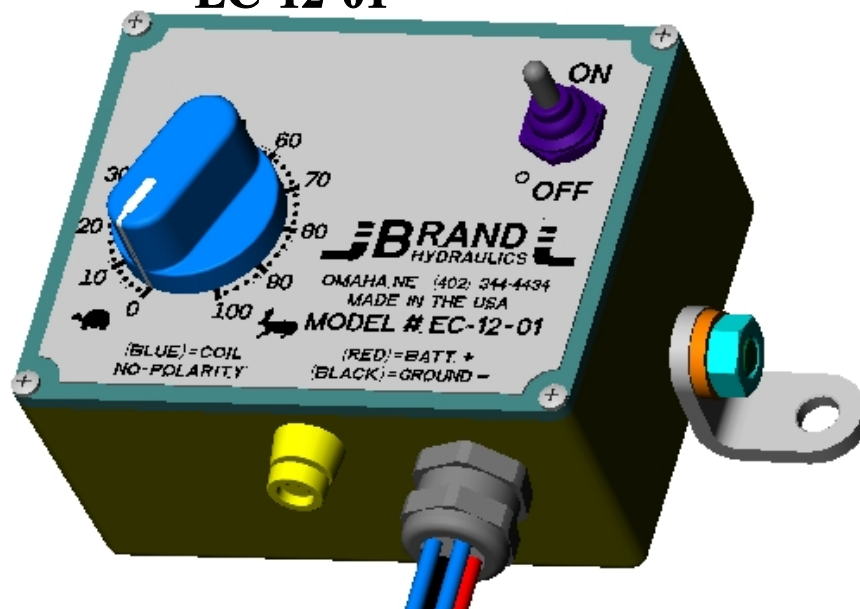

FEATURES:

- **RUGGED ALUMINUM BOX CONSTRUCTION** to help prevent impact damage.
- **HEAVY-DUTY FOOT BRACKETS** for quick and secure mounting.
- **COLOR KEYED WIRE LEADS** for easy wiring and identification.
- **STANDARD 18 INCHES LONG BY 18-AWG** wire (Consult factory for special leads).
- **PULSE WIDTH MODULATED (PWM)** output to help reduce the effects of hysteresis.
- **WEATHERPROOF SEALS** on power switch, potentiometer, fuse holder, wire bushing and box lid.
- **EXTERNALLY MOUNTED FUSE HOLDER** for quick and easy fuse change.
- **SHORT CIRCUIT PROTECTION** to guard against over current conditions.
- **SMOOTH RAMP THERMAL OVERLOAD PROTECTION** to help protect against overheating.
- **INPUT PROTECTION** from voltage transients, load dumps, 2-battery jumps and reverse polarity hook-ups.
- **POWER SWITCH** is separate from main control knob for turning valve on and off without loss of flow setting.
- **CIRCUIT BOARD** is coated with a special conformal coating to guard against moisture.
- **OPTIONAL HIGH VISIBILITY LED** for indicating that the power switch is on.

SPECIFICATIONS:

- **Supply Voltage:** 12.70-18.00 VDC.
- **Output Voltage:** 12 VDC, regardless of input supply voltage between 12.70-18.00 VDC.
- **Output Current:** 1.5 A Max. 1.0 A Nominal.
- **PWM Frequency:** 100 hz Average.
- **Efficiency:** without "L" option: 90% @ 1.0 A.
- **Efficiency:** with "L" option: 85% @ 1.0 amp.
- **Operating Temp:** -40° to 176°F (-40° to 80°C)
- **Storage Temp:** -85° to 194°F (-65° to 90°C)
- **Approximate Weight:** 1.4 lbs. (0.64 kg).

MATERIALS:

- **All metal parts are stainless steel, nickel-plated and zinc plated** to help prevent corrosion.
- **The control knob is a unique thermal plastic rubber that provides a soft grip with a contemporary look.**

EC – GENERAL INFORMATION:

The Brand, electronic control box is designed to proportionally adjust the Brand EFC-Series valves and other proportional valves that meet the appropriate specifications. The controller’s design makes it suitable for use in harsh environments as well as protected installations. The box has extensive weather proofing features to help it stand up against everyday use in sun, rain, snow or anything else that Mother Nature can dish out.

The main control knob is used to linearly adjust the current going through the solenoid on the valve. A large knob and a single turn potentiometer with a large degree of rotation gives smooth and precise adjustments. The controller is Pulse Width Modulated (PWM), which helps reduce the effects of hysteresis.

Each controller produced is burned-in for 24 hours after assembly to assure the controller is operating properly and meets all specifications. There are also many other quality assurance procedures that our controllers go through before they are shipped. All tests are performed with up to date, state of the art test equipment that is calibrated to NIST standards by an independent laboratory on a yearly basis.

EC – COMPLETE LIST OF COMMON MODEL CODES:

- EC-12-01**..... Electronic control box.
- EC-12-01L**..... Electronic control box with LED.

EC – COMPLETE LIST OF OPTIONS AND ACCESSORIES:

- E1726**..... Fuse 1.5 amp.
- E1758**..... Switch boot seal.
- E1028**..... Surface mount standoff.
- E1049**..... Panel mount fuse holder.
- E1053**..... Red wire (16 awg).
- E1054**..... Black wire (16 awg).
- E1055**..... Blue wire (16 awg).
- E1747**..... Power switch.
- E1071**..... Potentiometer shaft seal.
- EWP0017**..... Wall-mount power supply with 6 ft. cord.
- WP001**..... Female weather-pack (Packard part no. 12015792).
- WP002**..... Male weather-pack (Packard part no. 12010973).

EC CURRENT VS. DIAL PLATE:

Current vs. Dial Plate for EC-12-01, EC-12-01L and EC-12-02

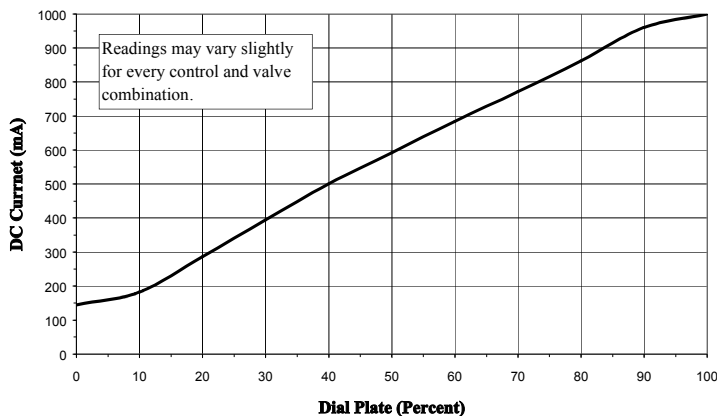

EC/EFC – SERIES SCHEMATIC DRAWING:

EC/EFC–SERIES SCHEMATIC DRAWING:

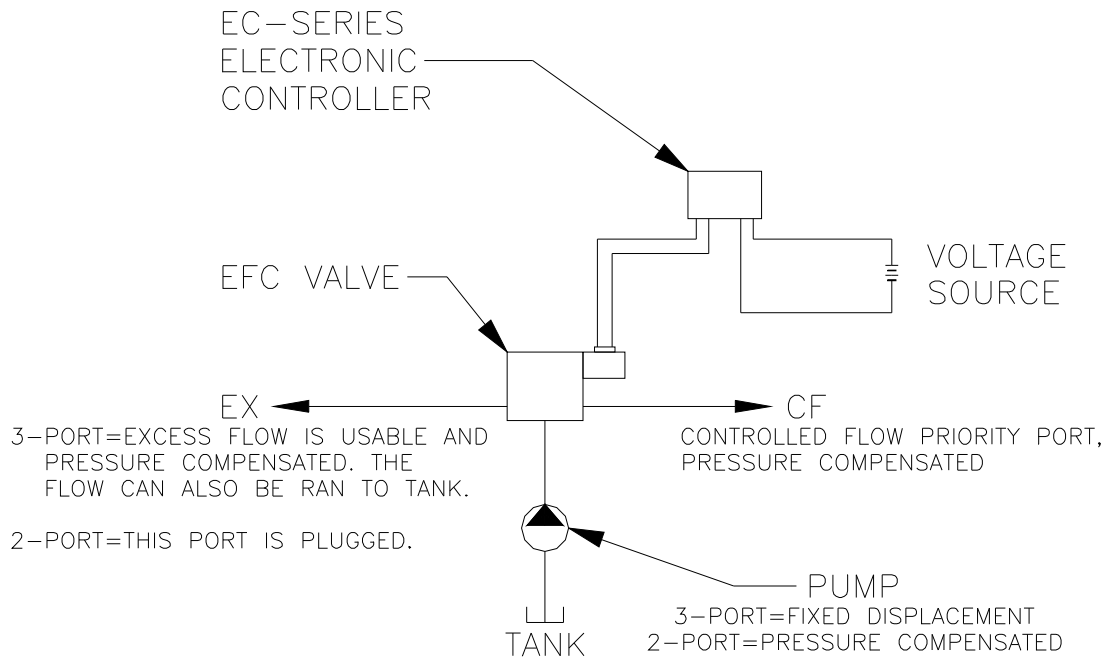

DIMENSIONAL DATA: inches & [millimeters]

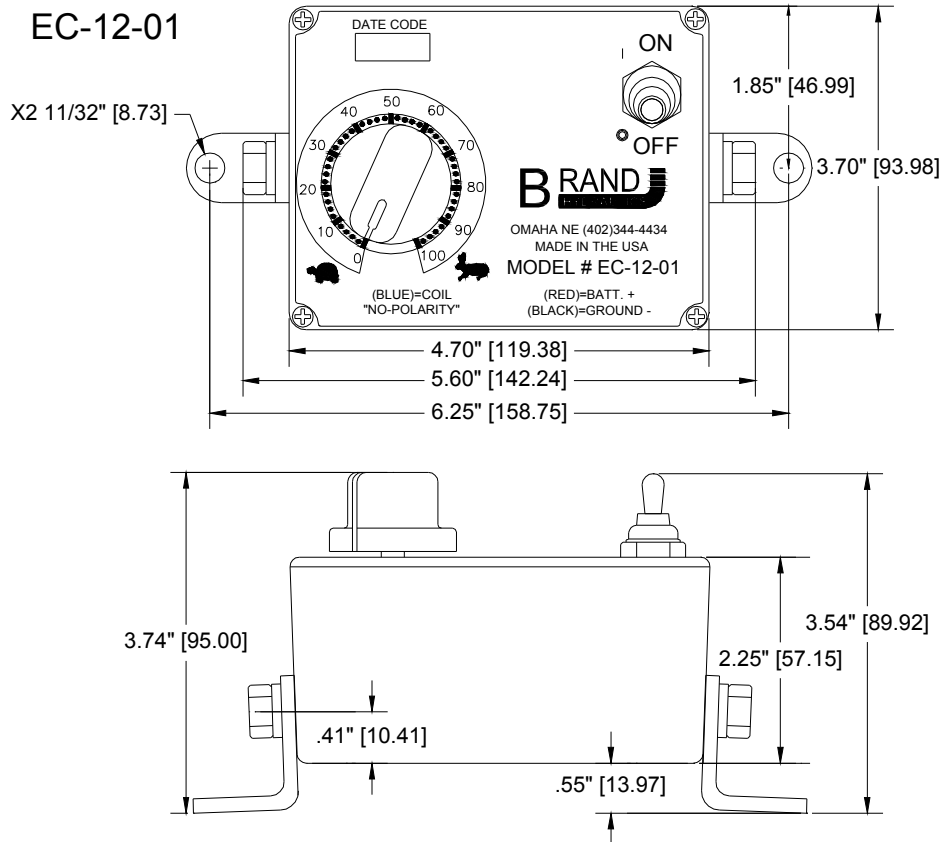

EC-12-01 AND EC-12-01L WIRING DIAGRAM:

WIRING DIAGRAM IS FOR EC-12-01 AND EC-12-01L

